

# 宁波顺达粉末冶金工业有限公司

阀  
座

底  
阀

产  
品  
规  
格  
表

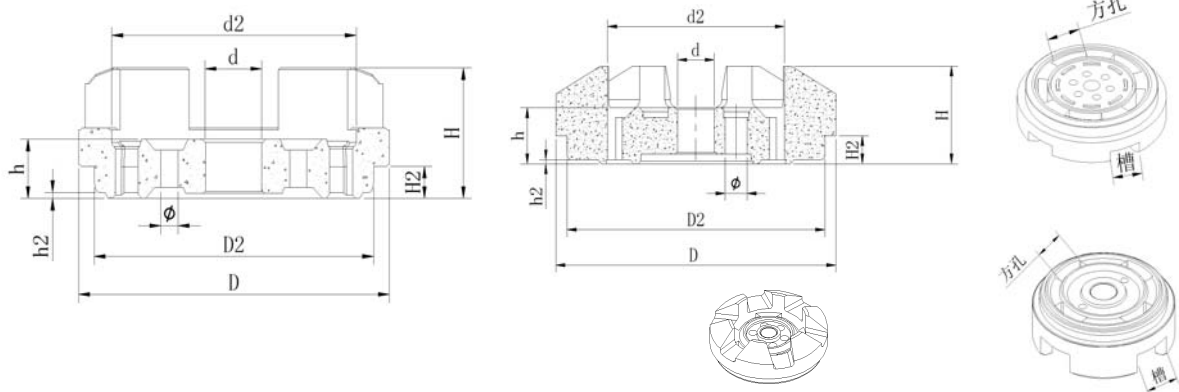

规格尺寸 编号代码	D	D2	d	d2	H	H2	h	h2	小孔	方孔	槽
SD028	33	30	5	22	11	3	7	0.5	N-Φ	4-10	4-10
SD036	35	32	5	25.6	11	3	6.2	0.5	4-2.0	4-10	4-10
SD083	33	30	5	22	11	3	7	0.5	N-Φ	4-10	4-10
SD084	38	35	5	24	14	3	7	0.5	N-Φ	4-10	6-7
SD098	28	25	6	20.5	11	3.8	5.5	0.8	3-1.8	4-6	4-10
SD188	29	25	5	21	11	3	7	0.5	2-1.4	4-8	4-10
SD241	29	25	6	22	10	3	6.5	1.0	6-3	-	
SD242	28	25	6	20.5	11	3.8	5.5	0.8	3-1.8	4-6	-
SD366	33	30	8	26	10	3.5	6	0.6	3-1.5	4-12	-
SD461	27.4	25	6	20.8	11.5	4	4.4	0.5	4-1.5	4-8	4-10
SD462	27.4	27	6	21.5	11.5	4	4.4	0.5	4-1.5	4-8	4-10
SD463	32.7	30	6	27	12.5	3.5	5.4	0.5	6-2	4-7.3	4-12
SD466	55	50	5	-	13	3.5	8	0.5	6-2.5	5-10	5-10
SD471	32.5	30	5.0	22.4	11.5	3.5	6.8	0.5	5-2.0	4-7	4-8
SD474	33	30	6	27	10	3.5	6	0.6	4-5.0	4-8	4-12
SD525	28.5	25	5	22	9	3	5	0.6	4-1.5	4-6	4-10
SD526	34.6	32	6	26	9.8	3	5.8	0.6	3-1.7	4-9	4-11.8
SD569	31	28.1	4.2	24	12.76	4.1	6.37	0.6	6-1.5	4-10.3	4-8
SD600	33	30	5	24.5	11.8	3	5	0.7	4-2.0	4-11	4-12
SD608	38.5	36	5	27	13.5	3.5	7	0.8	6-2.0	4-5.5	6-8
SD618	45	40	5	33	13	4	8	0.5	2-2	5-10	5-10
SD625	34.7	32	6	27	12.5	3.5	5.4	0.5	6-2	4-7.3	4-12
SD628	28	25	5	20	11.8	3.4	5	0.6	2-1.5	4-8	4-8
SD642	33	30	5	22	11	3	7	0.5	8-1.9	4-10	4-10
SD659	48	45	22	29	12	4	-	-	-	-	6-4
SD665	35	32	5	25.5	11	3	7	0.5	4-2.0	4-10	4-10



